

- | | |
|-----------------------|---------------------------|
| 1. Adjusting Screw | 12. O-Ring |
| 2. Lock Nut | 13. Body O-Ring |
| 3. Identification Tag | 14. Pusher Post |
| 4. Screw | 15. Body |
| 5. Spring Chamber | 16. Seat Ring |
| 6. Spring Button | 17. Composition Seat Disc |
| 7. Pressure Spring | 18. Piston |
| 8. Pusher Post Nut | 19. Strainer Screen |
| 9. Lock Washer | 20. Bottom Plug Gasket |
| 10. Pressure Plate | 21. Bottom Plug |

DESCRIPTION

The Type E-55 pressure reducing and regulating valve for cryogenic service is specifically designed for use in the pressure build-up circuit or pressure reducing in liquid or gas applications at extreme low temperatures.

The type E-55 pressure reducing valve is also available for final-line gas service. For specific information, consult the factory.

SPECIFICATION DATA

Service: Liquid or gas

Sizes: 1-1/4", 1-1/2", and 2"

Connections: Threaded female inlet and outlet

Body: Bronze

Temperature Rating: 150°F to -320°F

Maximum Initial Pressure: 400 psi

Outlet Pressure Range: 20-70, 50-150, 75-250

Capacity: For Specific capacity information, consult the factory.

CONSTRUCTION

Bronze body, Bronze trim, and Teflon Seat. Stainless steel body seat, Monel diaphragms, and Teflon O-ring diaphragm seals. Stainless steel pressure spring, Teflon bottom plug gasket, Stainless steel bolts, and Monel Strainer screen.

GENERAL INSTALLATION INSTRUCTIONS

Type E-55 regulators should be installed in the horizontal position with the spring chamber upright. For other installation requirements, consult the factory. For ease of operation and maintenance, it is suggested that manual shut-off valves be installed upstream and downstream from the valve. Before installing the valve, the piping and valve should be thoroughly flushed out to remove any foreign material. Install the valve with the inlet pipe fitted to the inlet connection identified on the valve body. Use a compatible sealant on the male pipe threads and do not over tighten the valve connections.

OPERATING INSTRUCTIONS

Adjusting the Delivery Pressure

The regulator's delivery pressure setting is adjusted by turning the adjusting screw (1) at

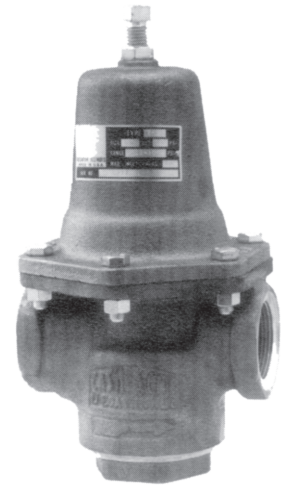

Type E-55 CRYOGENIC

PRESSURE REDUCING VALVE OR PRESSURE BUILD-UP REGULATOR

This Bulletin No.	TS-E55CRY
Date Of This Issue	AUGUST 2000
Supersedes Bulletin No.	TS-E55CRY
Dated	MARCH 1999

the top of the spring chamber (5), after loosening the adjusting screw lock nut (2). To increase the delivery pressure, turn the adjusting screw clock-wise (into the spring chamber). To decrease the delivery pressure, turn the adjusting screw counter-clockwise (out of the spring chamber). Tighten the adjusting screw lock nut after the adjustment has been made.

MAINTENANCE INSTRUCTIONS

CAUTION: Before attempting to replace any spare parts be sure to shut off all pressure connections to the valve. With the valve closed, however, system pressure could still be locked between the shut-off valve and the inlet and/or outlet sides of the regulator. Before proceeding with any valve service be certain to relieve the pressure from BOTH sides of the regulator.

Refer to the Type E-55 regulator exploded view for parts identification.

It is not necessary to remove the valve from the line for servicing.

Servicing the Strainer Screen (19), Seat Disc (17), and Bottom Plug Gasket (20)

1. Unscrew the bottom plug (21) and remove the strainer screen (19). The strainer screen will normally drop out when the plug is removed. Thoroughly clean the strainer screen and flush the valve body to remove any foreign material that may have collected around the strainer screen.
2. Inspect and if necessary replace the bottom plug gasket (20). If the gasket is to be replaced, remove all traces of the old gasket before reassembly.
3. Insert an Allen wrench in the bottom of the piston (18) and remove the piston by turning in a counter-clockwise direction.
4. Remove the Teflon seat disc (17) from the piston and replace if necessary.
5. Reassemble the valve in reverse order. After placing the valve in service, readjust the delivery pressure as detailed under Operating Instructions.

Servicing the Pressure Spring (7), Diaphragms (11), and Seat Ring (16)

1. Loosen the lock nut (2) 1/4 turn and turn the adjusting screw (1) counter-clockwise until the pressure spring (7) is no longer under tension.

Note: If the same pressure spring is being installed during reassembly, then when installing the adjusting screw, turn the screw clockwise until the lock nut just touches the spring chamber. When the valve is placed in service the pressure setting should be very close to the original setting.

2. Remove the six screws (4) securing the spring chamber (5) to the valve body (15). During reassembly, tighten the assembly bolts evenly in an alternate diagonal pattern.

3. Lift the spring chamber from the valve body and remove the spring button (6), and pressure spring (7).
4. Remove the piston (18), as described under Servicing the Strainer Screen (19), Seat Disc (17), and Bottom Plug Gasket (20), above.
5. Lift out the diaphragm and pusher post assembly (14) from the top of the valve body. Inspect the O-ring beneath the diaphragms and replace if necessary.
6. If it is necessary to replace the diaphragms, clamp the pusher post hex in a vise and remove the pusher post nut (8). Then remove the star lock washer (9), pressure plate (10), and diaphragms (11) from the pusher post. Install the same number of new diaphragms during reassembly.
7. Examine all parts for wear or damage and replace if necessary. The seat ring (16), can be removed with a socket wrench if it is found that the seating surface is damaged and replacement is necessary. During reassembly, place a small amount of compatible sealant on the threads.
8. Reassemble the parts in reverse order. After placing the valve in service, adjust the delivery pressure as outlined under Operating Instructions.

REPAIR PARTS INFORMATION

Refer to the exploded view of the Type E-55 regulator for parts identification.

SPECIFICATIONS

Each Type E-55 pressure regulator is equipped with a pressure spring selected to provide the desired outlet or reduced pressure setting. The range of adjustment or satisfactory "working range" of individual springs is shown in the Spring Range chart for each valve size. Every

regulator has the "set" pressure and range of adjustment stamped on the identification tag fastened to the valve. The ranges shown below are recommended for best performance.

SPRING RANGES

VALVE SIZES	PART NUMBERS & RANGE OF ADJUSTMENT (in psi)		
	1-1/4"	#8773	#12913
1-1/2", 2"	20-70	50-150	75-300

DIMENSIONS

VALVE SIZE	DIMENSIONS			SHIP. WT. (lbs.)
	A	B	C	
1-1/4"	5-5/8"	7-7/8"	3-1/4"	17
1-1/2"	5-5/8"	7-7/8"	3-1/4"	17
2"	5-3/4"	8-1/2"	2-7/8"	17

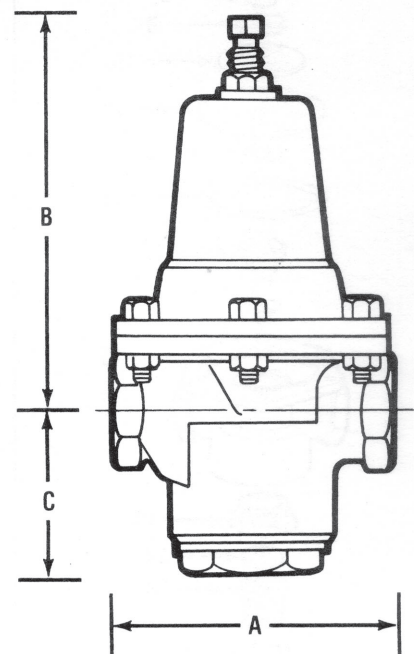

HOW TO ORDER

To order repair parts, refer to the exploded view of the Type E-55 to identify the part required. When ordering, please use the names listed and provide the valve serial number stated on the identification tag. Also state the following:

"Repair Parts for Type E-55 Cryogenic Service" and provide:

1. Valve size
2. Service
3. Inlet pressure
4. Outlet or delivery pressure range and setting

5. Part description
6. Quantity of each part
7. Valve assembly or serial number stated on the metal identification tag under the adjusting screw lock nut.